

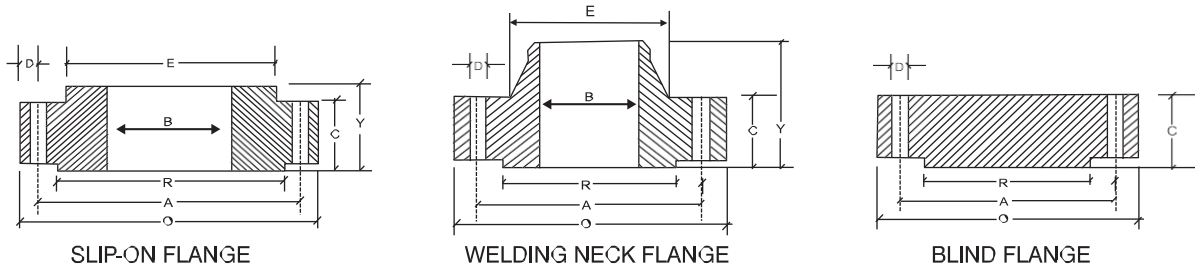

DIMENSIONS OF FORGED FLANGES ANSI 16.5



ASA 150 CLASS

Nominal Pipe Size	Flange Dia	Dia of Bolt Circle	Dia of Bolt Holes	No. of Holes	Thk of Flange	Dia of Hub	Length Through Hub			Dia of Bore		Dia of R/F	Depth of Socket	Pipe Dia	
							S/O & S/W	W/N	L/J	S/O & S/W	L/J				
(MM) (INCH.)	O	A	D		C	E	Y	Y	Y	B	B	R	F	X	
15	1/2	88.9	60.3	15.9	4	11.1	30.2	15.9	47.6	15.9	22.3	22.9	34.9	9.5	21.33
20	3/4	98.4	69.8	15.9	4	12.7	38.1	15.9	52.4	15.9	27.7	28.2	42.9	11.1	26.67
25	1	107.9	79.4	15.9	4	14.3	49.2	17.5	55.6	17.5	34.5	35.0	50.8	12.7	33.40
32	1 1/4	117.5	88.9	15.9	4	15.9	58.7	20.6	57.1	20.6	43.2	43.7	63.5	14.3	42.16
40	1 1/2	127.0	98.4	15.9	4	17.5	65.1	22.2	61.9	22.2	49.5	50.0	73.0	15.9	48.26
50	2	152.4	120.6	19.0	4	19.0	77.8	25.4	63.5	25.4	62.0	62.5	92.1	17.5	60.31
65	2 1/2	177.8	139.7	19.0	4	22.2	90.5	28.6	69.8	28.6	74.7	75.4	104.8	19.0	73.02
80	3	190.5	152.4	19.0	4	23.8	107.9	30.2	69.8	30.2	90.7	91.4	127.0	20.6	88.90
100	4	228.6	190.5	19.0	8	23.8	134.9	33.3	76.2	33.3	116.1	116.8	157.2	23.8	114.30
125	5	254.0	215.9	22.2	8	23.8	163.5	36.5	88.9	36.5	143.8	144.5	185.7	23.8	141.30
150	6	279.4	241.3	22.2	8	25.4	192.1	39.7	88.9	39.7	170.7	171.4	215.9	27.0	168.27
200	8	342.9	298.4	22.2	8	28.6	246.1	44.4	101.6	44.4	221.5	222.2	269.9	31.7	219.07
250	10	406.4	361.9	25.4	12	30.2	304.8	49.2	101.6	49.2	276.3	277.4	323.8	33.3	273.05
300	12	482.6	431.8	25.4	12	31.8	365.1	55.6	114.3	55.6	327.1	328.2	381.0	39.7	323.85
350	14	533.4	476.2	28.6	12	34.9	400.0	57.1	127.0	79.4	359.1	360.2	412.7	41.3	355.60
400	16	596.9	539.7	28.6	16	36.5	457.2	63.5	127.0	87.3	410.5	411.2	469.9	44.4	406.40
450	18	635.0	577.8	31.7	16	39.7	504.8	68.3	139.7	96.8	461.8	462.3	533.4	49.2	457.20
500	20	698.5	635.0	31.7	20	42.9	558.8	73.0	144.5	103.2	513.1	514.3	584.2	54.0	508.00
600	24	812.8	749.3	34.9	20	47.6	663.6	82.5	152.4	111.1	615.9	615.9	692.1	63.5	609.60

All Dimensions are in Millimeters • Flanges except Lap Joint will be furnished with (1.6mm) Raised Face, which is included in Thickness(C) and Length through Hub(Y).

ASA 300 CLASS

Nominal Pipe Size	Flange Dia	Dia of Bolt Circle	Dia of Bolt Holes	No. of Holes	Thk of Flange	Dia of Hub	Length Through Hub			Dia of Bore		Dia of R/F	Depth of Socket	Pipe Dia	
							S/O & S/W	W/N	L/J	S/O & S/W	L/J				
(MM) (INCH.)	O	A	D		C	E	Y	Y	Y	B	B	R	F	X	
15	1/2	95.2	66.7	15.9	4	14.3	38.1	22.2	52.4	22.2	22.3	22.9	34.9	9.5	21.33
20	3/4	117.5	82.5	19.0	4	15.9	47.6	25.4	57.1	25.4	27.7	28.2	42.9	11.1	26.67
25	1	123.8	88.9	19.0	4	17.5	54.0	27.0	61.9	27.0	34.5	35.0	50.8	12.7	33.40
32	1 1/4	133.3	98.4	19.0	4	19.0	63.5	27.0	65.1	27.0	43.2	43.7	63.5	14.3	42.16
40	1 1/2	155.6	114.3	22.2	4	20.6	69.8	30.2	68.3	30.2	49.5	50.0	73.0	15.9	48.26
50	2	165.1	127.0	19.0	8	22.2	84.1	33.3	69.8	33.3	62.0	62.5	92.1	17.5	60.31
65	2 1/2	190.5	149.2	22.2	8	25.4	100.0	38.1	76.2	38.1	74.7	75.4	104.8	19.0	73.02
80	3	209.5	168.3	22.2	8	28.6	117.5	42.9	79.4	42.9	90.7	91.4	127.0	20.6	88.90
100	4	254.0	200.0	22.2	8	31.8	146.0	47.6	85.7	47.6	116.1	116.8	157.2	23.8	114.30
125	5	279.4	234.9	22.2	8	34.9	177.8	50.8	98.4	50.8	143.8	144.5	185.7	-	141.30
150	6	317.5	269.9	22.2	12	36.5	206.4	52.4	98.4	52.4	170.7	171.4	215.9	-	168.27
200	8	381.0	330.2	25.4	12	41.3	260.3	61.9	111.1	61.9	221.5	222.2	269.9	-	219.07
250	10	444.5	387.3	28.6	16	47.6	320.7	66.7	117.5	95.2	276.3	277.4	323.8	-	273.05
300	12	520.7	450.8	31.7	16	50.8	374.6	73.0	130.2	101.6	327.1	328.2	381.0	-	323.85
350	14	584.2	514.3	31.7	20	54.0	425.4	76.2	142.9	111.1	359.1	360.2	412.7	-	355.60
400	16	647.7	571.5	34.9	20	57.2	482.6	82.5	146.0	120.6	410.5	411.2	469.9	-	406.40
450	18	711.2	628.5	34.9	24	60.3	533.4	88.9	158.7	130.2	461.8	462.3	533.4	-	457.20
500	20	774.7	685.8	34.9	24	63.5	587.4	95.2	161.9	139.7	513.1	514.3	584.2	-	508.00
600	24	914.4	812.8	41.3	24	69.8	701.7	106.4	168.3	152.4	615.9	615.9	692.1	-	609.60

All Dimensions are in Millimeters • Flanges except Lap Joint will be furnished with (1.6mm) Raised Face, which is included in Thickness(C) and Length through Hub(Y).

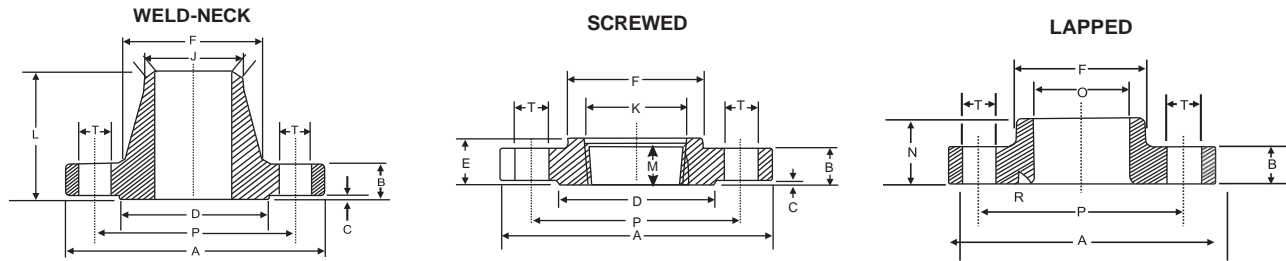

DIMENSIONS OF CLASS 600 FLANGES AS PER ANSI B 16.5

N.B.	A	B	C	D	E	F	G	H	J	K	L	M	N	O	P	R	T	No. of Holes
15	95	14.3	6.4	35	22	38	22.4	9.5	21.3	23.5	52	16	22	23.0	66.7	3.0	15.9	4
20	117	15.9	6.4	43	25	48	27.7	11.0	26.7	29.0	57	16	25	28.0	82.6	3.0	19.0	4
25	124	17.5	6.4	51	27	54	34.5	12.5	33.4	36.0	62	17	27	35.0	88.9	3.0	19.0	4
32	133	20.6	6.4	64	29	64	43.2	14.5	42.2	44.5	67	21	29	43.5	98.4	5.0	19.0	4
40	156	22.2	6.4	73	32	70	49.5	16.0	48.3	50.5	70	22	32	50.0	114.3	6.5	22.2	4
50	165	25.4	6.4	92	37	84	62.0	17.5	60.3	63.5	73	29	37	62.5	127.0	8.0	19.0	8
65	190	28.6	6.4	105	41	100	74.7	19.0	73.0	76.0	79	32	41	75.5	149.2	8.0	22.2	8
80	210	31.8	6.4	127	46	117	90.7	20.5	88.9	92.0	83	35	46	91.5	168.3	9.5	22.2	8
90	229	34.9	6.4	140	49	133	103.4	-	101.6	105.0	86	40	49	104.0	184.2	9.5	25.4	8
100	273	38.1	6.4	157	54	152	116.1	-	114.3	118.0	102	41	54	117.0	215.9	11.0	25.4	8
125	330	44.4	6.4	186	60	189	143.8	-	141.3	145.0	114	48	60	145.0	266.7	11.0	28.6	8
150	356	47.6	6.4	216	67	222	170.7	-	168.3	171.0	117	51	67	171.0	292.1	12.5	28.6	12
200	419	55.6	6.4	270	76	273	221.5	-	219.1	222.0	133	57	76	222.0	349.2	12.5	31.8	12
250	508	63.5	6.4	324	86	343	276.4	-	273.0	276.0	152	65	111	277.0	431.8	12.5	34.9	16
300	559	66.7	6.4	381	92	400	327.2	-	323.9	329.0	156	70	117	328.0	489.0	12.5	34.9	20
350	603	69.8	6.4	413	94	432	359.2	-	355.6	360.0	165	73	127	360.0	527.0	12.5	38.1	20
400	686	76.2	6.4	470	106	495	410.5	-	406.4	411.0	178	78	140	411.0	603.2	12.5	41.3	20
450	743	82.6	6.4	533	117	546	461.8	-	457.2	462.0	184	79	152	462.0	654.0	12.5	44.4	20
500	813	88.9	6.4	584	122	610	513.1	-	508.0	513.0	190	83	165	514.0	723.9	12.5	44.4	24
600	940	101.6	6.4	692	140	718	616.0	-	609.6	614.0	203	92	184	616.0	838.2	12.5	50.8	24

DIMENSIONS OF CLASS 900 FLANGES AS PER ANSI B 16.5

N.B.	A	B	C	D	E	F	G	H	J	K	L	M	N	O	P	R	T	No. of Holes
15	121	22.2	6.4	35	32	38	22.4	9.5	21.3	23.5	60	22	32	23.0	82.6	3.0	22.2	4
20	130	25.4	6.4	43	35	44	27.7	11.0	26.7	29.0	70	25	35	28.0	88.9	3.0	22.2	4
25	149	28.6	6.4	51	41	52	34.5	12.5	33.4	36.0	73	29	41	35.0	101.6	3.0	25.4	4
32	159	28.6	6.4	64	41	64	43.2	14.5	42.2	44.5	73	30	41	43.5	111.1	5.0	25.4	4
40	178	31.8	6.4	73	44	70	49.5	16.0	48.3	50.5	83	32	44	50.0	123.8	6.5	28.6	4
50	216	38.1	6.4	92	57	105	62.0	17.5	60.3	63.5	102	38	57	62.5	165.1	8.0	25.4	8
65	244	41.3	6.4	105	64	124	74.7	19.0	73.0	76.0	105	48	64	75.5	190.5	8.0	28.6	8
80	267	47.6	6.4	127	73	133	-	-	88.9	92.0	117	51	73	91.5	203.2	9.5	31.8	8
100	311	54.0	6.4	157	91	162	-	-	114.3	118.0	124	57	91	117.0	241.3	11.0	34.9	8
125	325	73.0	6.4	186	105	197	-	-	141.3	145.0	156	64	105	145.0	292.1	11.0	41.3	8
150	394	82.6	6.4	216	119	229	-	-	168.3	171.0	171	70	119	171.0	317.5	12.5	38.1	12
200	483	92.1	6.4	270	143	292	-	-	219.1	222.0	213	75	143	222.0	393.7	12.5	44.4	12
250	584	108.0	6.4	324	159	368	-	-	273.0	276.0	254	84	178	277.0	482.6	12.5	50.8	12
300	673	123.8	6.4	381	181	451	-	-	323.9	329.0	283	92	219	328.0	571.5	12.5	54.0	16
350	749	133.4	6.4	413	-	495	-	-	356.6	-	298	-	241	360.0	635.0	12.5	60.3	16
400	826	146.1	6.4	470	-	552	-	-	406.4	-	311	-	260	411.0	704.8	12.5	66.7	16
450	914	161.9	6.4	533	-	597	-	-	457.2	-	327	-	276	462.0	774.7	12.5	73.0	16
500	984	178.0	6.4	584	-	641	-	-	508.0	-	356	-	292	514.0	831.8	12.5	79.4	16
600	1168	203.0	6.4	692	-	762	-	-	609.6	-	406	-	330	616.0	990.6	12.5	92.0	16

- 1) All dimensions are in Millimeters
- 2) Flanges except Lap Joint will be furnished with (1.6) Raised Face, which is included in "Thickness(C)" and "Length through Hub(Y)".



DIMENSIONS OF FORGED FLANGES ANSI B 16.5

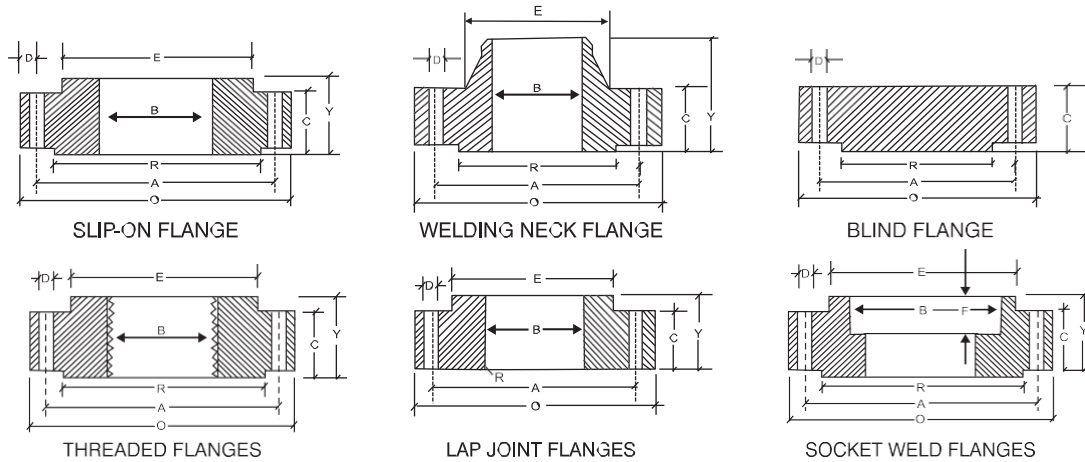

ASA 1500 CLASS

Nominal Pipe Size	Flange Dia	Dia of Bolt Circle	Dia of Bolt Holes	No. of Holes	Thk of Flange	Dia of Hub	Length Through Hub			Dia of Bore		Dia of R/F	Depth of Socket	Pipe Dia	
							S/O & S/W	W/N	L/J	S/O & S/W	L/J				
(MM)	(INCH.)	O	A	D	C	E	Y	Y	Y	B	B	R	F	X	
For Dimensions from 1/2" to 2 1/2" kindly refer ASA 900 LBS Table.															
80	3	266.7	203.2	31.7	8	47.6	133.3	73.0	117.5	73.0	90.7	91.4	127.0	-	88.90
100	4	311.1	241.3	34.9	8	54.0	161.9	90.5	123.0	90.4	116.1	116.8	157.2	-	114.30
125	5	374.6	292.1	41.3	8	73.0	196.8	104.8	155.6	104.8	143.8	144.5	185.7	-	141.30
150	6	393.7	317.5	38.1	12	82.6	228.6	119.1	171.4	119.1	170.7	171.4	215.9	-	168.27
200	8	482.6	393.7	44.4	12	92.1	292.1	142.9	212.7	142.8	221.5	222.2	269.9	-	219.07
250	10	584.2	482.6	50.8	12	107.9	368.3	158.7	254.0	177.8	276.3	277.3	323.8	-	273.05
300	12	673.1	571.5	54.0	16	123.8	450.8	181.0	282.5	218.9	327.1	328.1	381.0	-	323.85

All Dimensions are in Millimeters • Flanges except Lap Joint will be furnished with(6.35mm) Raised Face, which is not included in Thickness(C) and Length through Hub(Y).

ASA 2500 CLASS

Nominal Pipe Size	Flange Dia	Dia of Bolt Circle	Dia of Bolt Holes	No. of Holes	Thk of Flange	Dia of Hub	Length Through Hub			Dia of Bore		Dia of R/F	Depth of Socket	Pipe Dia	
							S/O & S/W	W/N	L/J	S/O & S/W	L/J				
(MM)	(INCH.)	O	A	D	C	E	Y	Y	Y	B	B	R	F	X	
15	1/2	133.3	88.9	22.2	4	30.2	42.9	39.7	73.0	39.7	22.3	22.3	34.9	-	21.33
20	3/4	139.7	95.3	22.2	4	31.7	50.8	42.9	79.4	42.9	27.7	27.7	42.9	-	26.67
25	1	158.7	107.9	25.4	4	34.9	57.1	47.7	88.9	47.7	34.5	34.5	50.8	-	33.40
32	1 1/4	184.1	130.2	28.6	4	38.1	73.0	52.4	95.2	52.4	43.2	43.2	63.5	-	42.16
40	1 1/2	203.2	146.0	31.7	4	44.4	79.4	60.3	111.1	60.3	49.5	49.5	73.0	-	48.26
50	2	234.9	171.4	28.6	8	50.8	95.2	69.8	127.0	69.8	62.4	62.0	92.1	-	60.31
65	2 1/2	266.7	196.8	31.7	8	57.1	114.3	79.4	142.9	79.4	74.7	74.7	104.8	-	73.02
80	3	304.8	228.6	34.9	8	66.7	133.3	92.1	168.3	92.1	90.7	90.7	127.0	-	88.90
100	4	355.6	273.0	41.2	8	76.2	165.1	107.9	190.5	107.9	116.1	116.1	157.2	-	114.30
125	5	419.1	323.8	47.6	8	92.1	203.2	130.0	228.6	130.0	143.8	143.8	185.7	-	141.30
150	6	482.6	368.3	54.0	8	107.9	234.9	152.4	273.0	152.4	170.7	170.7	215.9	-	168.27
200	8	552.4	438.1	54.0	12	127.0	304.8	177.8	317.5	177.8	221.5	221.5	269.9	-	129.07
250	10	673.1	539.7	66.7	12	165.1	374.6	228.6	419.1	228.6	276.3	276.3	323.8	-	273.05
300	12	762.0	619.1	73.0	12	184.1	441.3	254.0	463.5	254.0	327.1	327.1	381.0	-	323.85

All Dimensions are in Millimeters • Flanges except Lap Joint will be furnished with(6.35mm) Raised Face, which is not included in Thickness(C) and Length through Hub(Y).



CLASS 150 FLANGES SERIES 'A'

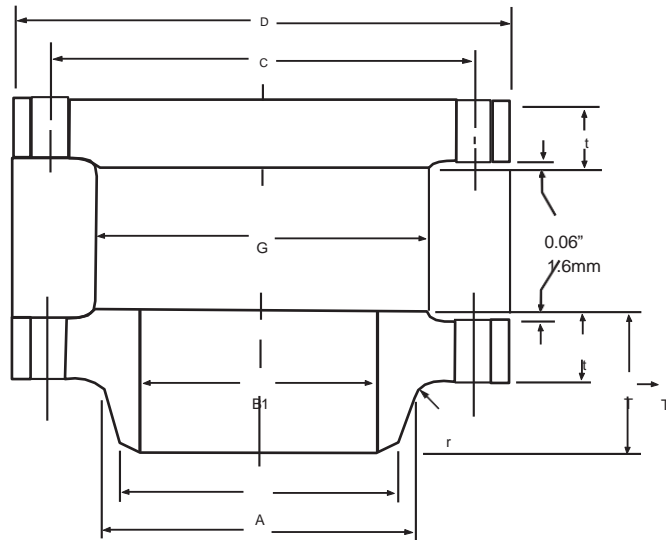

MSS SP44 FORGED FLANGES

Unit:mm

Nominal Pipe Size	Outside Diam	O.D. of Raised Face	Diam at Base of Hub	Thick-ness	BORE		Length Thru Hub	Diam. of Hub of Bevel	Radius of Base of Hub	DRILLING			Approximate Weight (kg) 9.5mm	
					Wall Thickness					Bolt Circle Diam	Number of Holes	Diam. Of Holes		
					9.5mm	12.7mm							B1	T1
12	483	381.0	365.3	31.8	304.8	298.5	114.3	323.9	9.7	431.8	12	25.4	-	-
14	533	412.8	400.1	35.1	336.6	330.2	127.0	355.6	9.7	476.3	12	28.4	-	-
16	597	469.9	457.2	36.6	387.4	381.0	127.0	406.4	9.7	539.8	16	28.4	-	-
18	635	533.4	505.0	39.6	438.2	431.8	139.7	457.2	9.7	577.9	16	31.8	-	-
20	699	584.2	558.8	42.9	489.0	482.6	144.5	508.2	9.7	635.0	20	31.8	-	-
22	749	641.4	609.6	46.0	539.8	533.4	149.4	558.8	9.7	692.2	20	35.1	-	-
24	813	692.2	663.4	47.8	590.6	584.2	152.4	609.6	9.7	749.3	20	35.1	-	-
26	870	749.3	676.1	68.3	641.4	635.0	120.7	To specified by purchaser	9.7	806.5	24	35.1	147	306
28	927	800.1	726.9	71.4	692.2	685.8	125.5		11.2	863.6	28	35.1	165	363
30	984	857.3	781.1	74.7	743.0	736.6	136.7		11.2	914.4	28	35.1	193	430
32	1060	914.4	831.9	80.8	793.8	787.4	144.5		11.2	977.9	28	41.1	243	537
34	1111	965.2	882.7	82.6	844.6	838.2	149.4		12.7	1028.7	32	41.1	258	600
36	1168	1022.4	933.5	90.4	895.4	889.0	157.0		12.7	1085.9	32	41.1	306	730
38	1238	1073.2	990.6	87.4	946.2	939.8	157.2		12.7	1149.4	32	41.1	342	794
40	1289	1124.0	1041.4	90.4	997.0	990.6	163.6		12.7	1200.2	36	41.1	368	893
42	1346	1193.8	1092.2	96.8	1047.8	1041.4	171.5		12.7	1257.3	36	41.1	422	1044
44	1403	1244.6	1143.0	101.6	1098.6	1092.2	177.8		12.7	1314.5	40	41.1	470	1190
46	1454	1295.4	1196.8	103.1	1149.4	1143.0	185.7		12.7	1365.3	40	41.1	503	1299
48	1511	1358.9	1247.6	108.0	1200.2	1193.8	192.0		12.7	1422.4	44	41.1	556	1470
50	1568	1409.7	1301.8	111.3	1251.0	1244.6	203.2		12.7	1479.6	44	47.8	598	1616
52	1626	1460.5	1352.6	115.8	1301.8	1295.4	209.6		12.7	1536.7	44	47.8	661	1817
54	1683	1511.3	1403.4	120.7	1352.6	1346.2	215.9		12.7	1593.9	44	47.8	730	2031
56	1746	1574.8	1457.5	124.0	1403.4	1397.0	228.6		12.7	1651.0	48	47.8	813	2244
58	1803	1625.6	1508.3	128.5	1454.2	1447.8	235.0		12.7	1708.2	48	47.8	890	2491
60	1854	1676.4	1559.1	131.8	1505.0	1498.6	239.8		12.7	1759.0	52	47.8	936	2697

■ Class 150 flanges will be furnished with 0.06" (1.6mm) raised face, which is included 'Thickness' (t) and 'Length through Hub' (T1)

■ Dimensional tolerance are in accordance with ANSI B16.5



CLASS 300 FLANGES SERIES 'A'

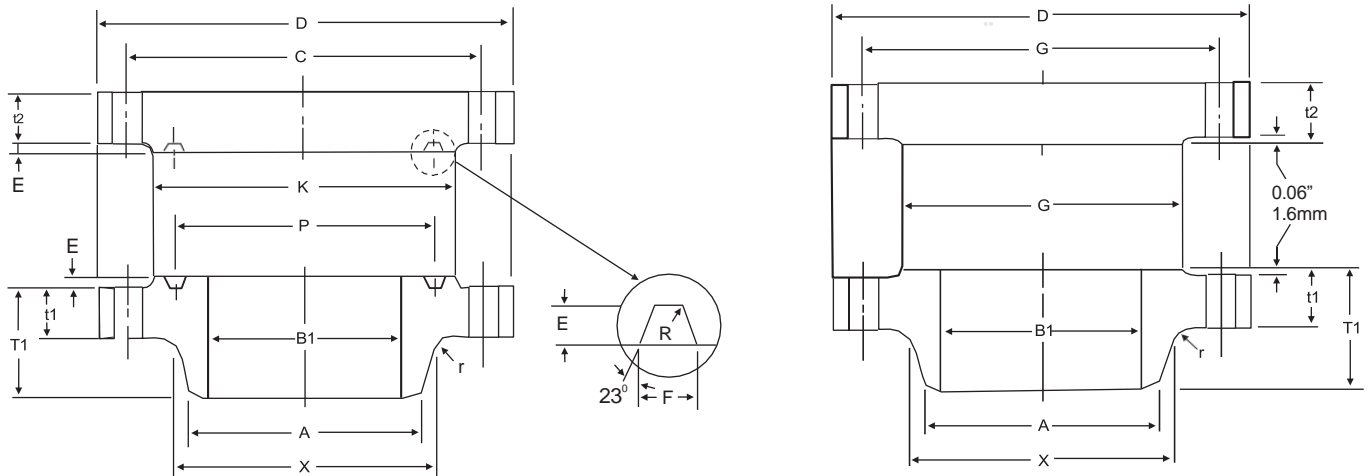

MSS SP44 FORGED FLANGES

Unit : mm

Nominal Pipe Size	Outside Diam	O. D. of Raised Face	Diam At Base of Hub	Thickness		BORE		Length Thru Hub	Diam of Hub of Bevel	Radius of Fillet	DRILLING			Approximate Weight (kg) 9.5mm	
				Welding Neck	Blind	Wall Thickness					Bolt Circle Diam	Number of Holes	Diam Of Holes	WN	BL
						9.5mm	12.7mm								
D	G	X	t1	t2	B1		T1	A	r	C					
12	521	381	347.7	50.8	50.8	304.8	298.5	130.0	323.9	9.7	450.9	16	31.8	-	-
14	584	412.8	425.5	53.8	53.8	336.6	330.2	142.7	355.6	9.7	514.4	20	31.8	-	-
16	648	469.9	482.6	57.2	57.2	387.4	381.0	146.1	406.4	9.7	571.5	20	35.1	-	-
18	711	533.4	533.4	60.5	60.5	468.2	431.8	158.8	457.2	9.7	628.7	24	35.1	-	-
20	775	584.2	587.2	63.5	63.5	489.0	482.6	162.1	508.0	9.7	685.8	24	35.1	-	-
22	838	641.4	641.4	66.5	66.5	539.8	533.4	165.1	558.8	9.7	743.0	24	41.1	-	-
24	914	692.2	701.5	69.9	69.9	590.6	584.2	168.1	609.6	9.7	812.8	24	41.1	-	-
26	972	749.3	720.9	79.2	84.1	641.4	635.0	184.2	660.4	9.7	876.3	28	44.5	275	460
28	1035	800.1	774.7	85.9	90.4	692.2	685.8	196.9	711.2	11.2	939.8	28	44.5	340	566
30	1092	857.3	827.0	91.9	95.3	743.0	736.6	209.6	762.0	11.2	997.0	28	47.8	389	663
32	1149	914.4	881.1	98.6	100.1	793.8	787.4	222.3	812.8	11.2	1054.1	28	50.8	445	770
34	1207	965.2	936.8	101.6	104.6	844.6	838.2	231.6	863.6	12.7	1104.9	28	50.8	498	894
36	1270	1022.4	990.6	104.6	111.3	895.4	889.0	241.3	914.4	12.7	1168.4	32	53.8	563	1040
38	1168	1028.7	993.6	108.0	108.0	946.2	939.8	180.8	T0 specified by purchaser	12.7	1092.2	32	41.1	307	872
40	1238	1085.9	1047.8	114.3	114.3	997.0	990.6	193.5		12.7	1155.7	32	44.5	392	1035
42	1289	1136.7	1098.6	119.1	119.1	1047.8	1041.4	200.2		12.7	1206.5	32	44.5	409	1173
44	1353	1193.8	1149.4	124.0	124.0	1198.6	1092.2	206.2		12.7	1263.7	32	47.8	464	1340
46	1416	1244.6	1203.5	128.5	128.5	1149.4	1143.0	215.9		12.7	1320.8	28	50.8	544	1600
48	1467	1301.8	1254.3	133.4	133.4	1200.2	1193.8	223.8		12.7	1371.6	32	50.8	569	1700
50	1530	1358.9	1305.1	139.7	139.7	1251.0	1244.6	231.6		12.7	1428.8	32	53.8	645	1936
52	1581	1409.7	1355.9	144.5	144.5	1301.8	1295.4	238.3		12.7	1479.6	32	53.8	694	2143
54	1657	1466.9	1409.7	152.4	152.4	1352.6	1346.2	252.5		12.7	1549.4	28	60.5	834	2486
56	1708	1517.7	1463.5	153.9	153.9	1403.4	1397.0	260.4		12.7	1600.2	28	60.5	882	2674
58	1759	1574.8	1514.3	158.8	158.8	1454.2	1447.8	266.7		12.7	1651.0	32	60.5	928	2913
60	1810	1625.6	1565.1	163.6	163.6	1505.0	1498.6	273.0		12.7	1701.8	32	60.5	989	3184

- Class 300 flanges will be furnished with 0.06" (1.6mm) raised face, which is included in 'Thickness' (t) and 'Length through Hub' (T1)
- Dimensional tolerances are in accordance with ANSI B 16.5



FLANGES API 605 ANSI ASME B 16.47 SERIES B FLANGES (API 605)

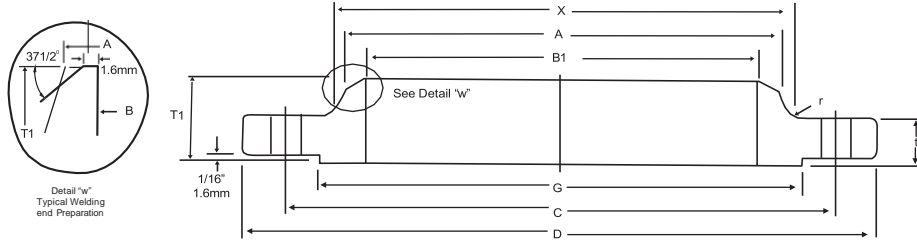

Class 75 Flanges

Unit : mm

Nominal Pipe Size	Outside Diam.	O. D. of Raised Face	Diam at Base of Hub	Thick-ness	BORE			Length Thru Hub	Diam of Hub of Bevel	Radius of Base of Hub	Bolt Circle Diam	Number of Holes	Diam of Holes	Approximate Weight (kg) 9.5mm wn
					Wall Thickness									
					6.35mm	9.5mm	12.7mm							
D	G	X	t	B1	T1	A	r	C						
26	762	704.9	676.1	33.3	647.7	641.4	635.0	58.7	661.9	7.9	723.9	36	19.1	29.01
28	813	755.7	726.9	33.3	698.5	692.2	685.8	62.0	712.7	7.9	774.7	40	19.1	31.01
30	864	806.5	777.7	33.3	749.3	743.0	736.6	65.0	763.5	7.9	825.5	44	19.1	35.06
32	914	857.3	828.5	35.1	800.1	793.8	787.4	69.9	814.3	7.9	876.3	48	19.1	48.03
34	965	908.1	879.3	35.1	850.9	844.6	838.2	73.2	865.1	7.9	927.1	52	19.1	50.03
36	1034	965.2	935.0	36.6	850.9	895.4	889.0	85.9	915.9	9.7	992.1	40	22.4	62.06
38	1084	1016.0	985.8	38.1	952.5	946.2	939.8	88.9	966.7	9.7	1042.9	40	22.4	70.05
40	1135	1066.8	1036.6	38.1	1003.3	997.0	990.6	91.9	1017.5	9.7	1093.7	44	22.4	74.05
42	1186	1117.6	1087.4	39.6	1054.1	1047.8	1041.4	95.3	1068.3	9.7	1144.5	48	22.4	77.09
44	1251	1174.8	1140.0	42.9	1104.9	1049.4	1143.0	104.6	1119.1	9.7	1203.5	36	25.4	82.08
46	1302	1225.6	1190.8	44.5	1155.7	1149.4	1143.0	108.0	1169.9	9.7	1254.3	40	25.4	105.01
48	1353	1276.4	1241.6	46.0	1206.5	1200.2	1193.8	111.3	1220.7	9.7	1305.1	44	25.4	120.03
50	1403	1327.2	1293.9	47.8	1257.3	1251.0	1244.6	115.8	1271.5	9.7	1355.9	44	25.4	134.28
52	1457	1378.0	1344.7	47.8	1301.8	1301.8	1295.4	120.7	1322.3	9.7	1409.7	48	25.4	142.18
54	1508	1428.8	1397.0	49.3	1358.9	1352.6	1346.2	125.5	1373.1	9.7	1460.6	48	25.4	180.15
56	1575	1485.9	1450.8	50.8	1409.7	1403.4	1397.0	134.9	1423.9	11.2	1521.0	40	28.4	184.58
58	1626	1536.7	1501.6	52.3	1460.5	1454.2	1447.8	138.2	1474.7	11.2	1571.8	44	28.4	195.56
60	1676	1587.5	1552.4	55.6	1511.3	1505.0	1498.6	144.5	1525.5	11.2	1622.6	44	28.4	210.20

Class 150 Flanges

Unit:mm

Nominal Pipe Size	Outside Diam.	O. D. of Raised Face	Diam at Base of Hub	Thick-ness		BORE			Length Thru Hub	Diam of Hub of Bevel	Radius of Base of Hub	Bolt Circle Diam	DRILLING		Approximate Weight (kg) 9.5mm	
				t	(BL)	Wall Thickness							Number of Holes	Diam of Holes	WN	BL
						6.35mm	9.5mm	12.7mm								
D	G	X	t	(BL)	B1	T1	A	r	C							
26	786	711.2	684.3	41.1	44.5	647.7	641.4	635.0	88.9	661.9	9.7	744.5	36	22.4	59	165
28	837	762.0	735.1	44.5	47.8	698.5	692.2	685.8	95.3	712.7	9.7	795.3	40	22.4	68	201
30	887	812.8	787.4	44.5	50.8	749.3	743.0	736.6	100.1	763.5	9.7	846.1	44	22.4	74	241
32	941	863.6	839.7	46.0	53.8	800.1	793.8	787.4	108.0	814.3	9.7	900.1	48	22.4	85	288
34	1005	920.8	892.0	49.3	57.2	850.9	844.6	838.2	110.2	865.1	9.7	957.3	40	25.4	103	349
36	1057	971.6	944.6	52.3	58.7	901.7	895.4	889.0	117.3	915.9	9.7	1009.7	44	25.4	117	397
38	1124	1022.4	997.0	53.8	63.5	952.5	946.2	939.8	124.0	968.2	9.7	1069.9	40	28.4	140	485
40	1175	1079.5	1049.3	55.6	66.5	1003.3	997.0	990.6	128.5	1019.0	9.7	1120.6	44	28.4	153	556
42	1226	1130.3	1101.9	58.7	68.3	1054.1	1047.8	1041.4	133.4	1069.8	11.2	1171.4	48	28.4	168	621
44	1276	1181.1	1152.7	60.5	71.4	1104.9	1098.6	1092.2	136.7	1120.6	11.2	1222.2	52	31.8	200	704
46	1341	1234.9	1205.0	62.0	74.7	1155.7	1149.4	1143.0	144.5	1171.4	11.2	1284.2	40	31.8	210	816
48	1392	1289.1	1257.3	65.0	77.7	1206.5	1200.2	1198.8	149.4	1222.2	11.2	1335.0	44	31.8	240	915
50	1443	1339.9	1308.1	68.3	80.8	1257.3	1251.0	1244.6	153.9	1273.0	11.2	1385.8	48	31.8	250	1021
52	1494	1390.7	1360.4	69.9	84.1	1308.1	1301.8	1295.4	157.2	1323.8	11.2	1436.6	52	31.8	266	1139
54	1549	1441.5	1412.7	71.4	87.4	1358.9	1352.6	1346.2	162.1	1374.6	11.2	1492.3	56	31.8	310	1274
56	1600	1492.3	1465.8	73.2	90.4	1409.7	1403.4	1397.0	166.6	1425.4	14.2	1543.1	60	31.8	306	1406
58	1675	1543.1	1516.1	74.7	93.5	1460.5	1454.2	1447.8	174.8	1476.2	14.2	1611.4	48	35.1	367	1596
60	1726	1600.2	1570.0	76.2	96.8	1511.3	1505.0	1498.6	179.3	1527.0	14.2	1662.2	52	35.1	410	1754

BORE (B1) of flanges is shall be specified by th the purchaser.

Class 75 flanges will ne furnished with 0.06" (1.6mm) raised face, which is included in 'Thickness' (t) and Length through hub' T1)



ANSI ASME B 16.47 CLASS 300 FLANGES SERIES B

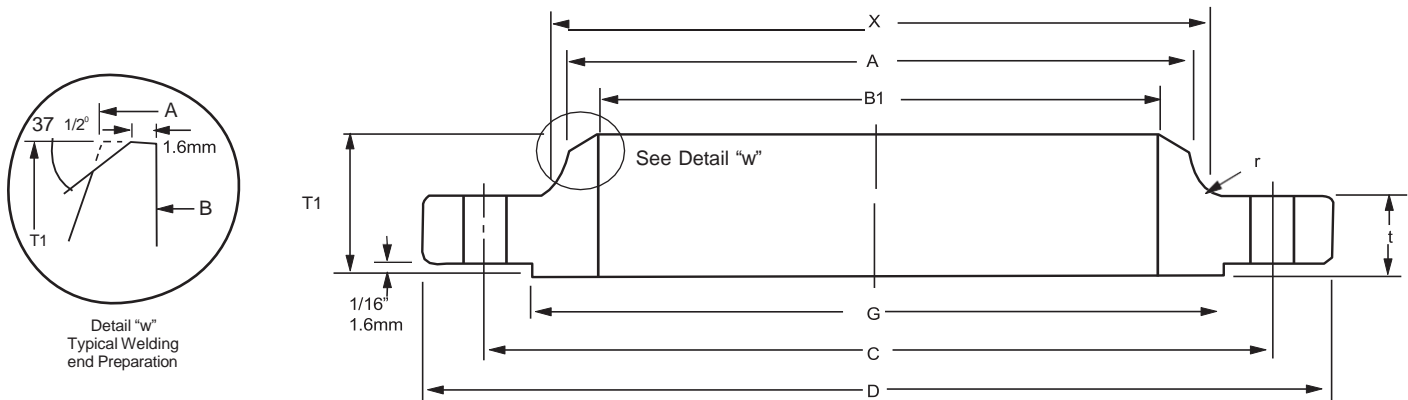

Unit : mm

Nominal Pipe Size	Outside Diam	O.D. of Raised Face	Diam. of Base of Hube	Diam. of Hub of Bevel	BORE			Length Thru Hub	Thick-ness		Radius of Base of Hub	DRILLING			Approximate Weight (Kg) 9.5 mm	
					Wall Thickness							Bolt Circle Diam.	Number of Holes	Diam of Holes		
					6.35 mm	9.5 mm	12.7 mm									
	D	G	X	A		B1		T1	t	(BL)	r	C			WN	BL
26	867	736.6	701.5	665.2	647.7	641.4	635.0	144.5	88.9	88.9	14.2	803.1	32	35.1	200	393
28	921	787.4	755.7	716.0	698.5	692.2	685.8	149.4	88.9	88.9	14.2	857.3	36	35.1	210	443
30	991	844.6	812.8	768.4	749.3	743.0	736.6	158.0	93.7	93.7	14.2	920.8	36	38.1	270	540
32	1054	901.7	863.6	819.2	800.1	793.8	787.4	168.1	103.1	103.1	15.7	977.9	32	41.1	330	677
34	1108	952.5	917.4	870.0	850.9	844.6	838.2	173.0	103.1	103.1	15.7	1031.7	36	41.1	360	747
36	1171	1009.7	965.2	920.8	901.7	895.4	889.0	180.8	103.1	103.1	15.7	1089.2	32	44.5	410	838
38	1222	1060.5	1016.0	971.6	952.5	946.2	939.8	192.0	111.3	111.3	15.7	1140.0	36	44.5	571	983
40	1273	1114.6	1066.8	1022.4	1003.3	997.0	990.6	198.4	115.8	115.8	15.7	1190.8	40	44.5	661	1110
42	1334	1168.4	1117.6	1074.7	1054.1	1047.8	1041.4	204.7	119.1	119.1	15.7	1244.6	36	47.8	721	1256
44	1384	1219.2	1173.2	1125.5	1104.9	1098.6	1092.2	214.4	127.0	127.0	15.7	1295.4	40	47.8	801	1441
46	1461	1270.0	1228.8	1176.3	1155.7	1149.4	1143.0	222.3	128.5	130.0	15.7	1365.3	36	50.8	971	1649
48	1511	1327.2	1277.9	1227.1	1206.5	1200.2	1193.8	223.8	128.5	134.9	15.7	1416.1	40	50.8	991	1829
50	1562	1378.0	1330.5	1277.9	1257.3	1251.0	1244.6	235.0	138.2	139.7	15.7	1466.9	44	50.8	1048	2021
52	1613	1428.8	1382.8	1328.7	1308.1	1301.8	1295.4	242.8	142.7	144.3	15.7	1517.1	48	50.8	1114	2223
54	1673	1479.6	1435.1	1379.5	1358.9	1352.6	1346.2	239.8	136.7	149.4	15.7	1577.8	48	50.8	1161	2486
56	1765	1536.7	1493.8	1422.4	1409.7	1403.4	1397.0	268.2	153.9	157.0	17.5	1651.0	36	60.5	1336	2913
58	1827	1593.9	1547.9	1481.1	1460.5	1454.2	1447.8	274.6	153.9	162.1	17.5	1712.0	40	60.5	1428	3218
60	1878	1651.0	1598.7	1531.9	1511.3	1505.0	1498.6	271.5	150.9	166.6	17.5	1763.8	40	60.5	1451	3504

Notes

1. Bore (B1) OF Flanges is shall be specified by the purchaser.
2. Class 300 Flanges will be furnished with 0.06* (1.6mm) raised face, which is included in 'Thickness' (t) and 'Length through Hub'T1)



SPECTACLE BLINDS

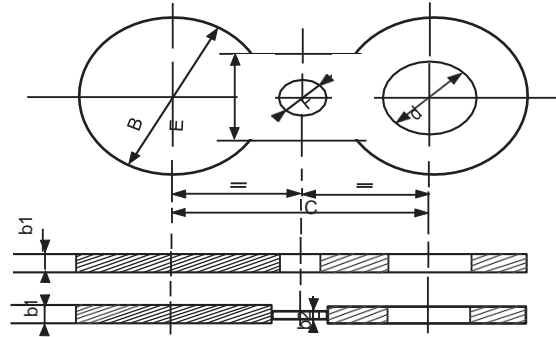

DN	150lbs							300lbs						
	B	d	C	E	b1	b2	F	B	d	C	E	b1	b2	F
1/2	44	16	60	25	6.5	4	16	51	16	67	30	6.5	4	16
3/4	54	22	70	30	6.5	4	16	63	22	83	35	6.5	4	16
1	63	28.5	79	35	6.5	4	16	70	28.5	89	40	6.5	4	16
1 1/4	73	35	89	40	6.5	4	16	79	35	98	45	6.5	4	16
1 1/2	82	41.5	98	50	6.5	4	16	92	41.5	114	55	6.5	4	23
2	101	54	121	50	6.5	4	19	108	54	127	28	6.5	4	16
2 1/2	120	66.5	140	50	6.5	4	19	127	66.5	149	35	6.5	4	23
3	133	79.5	152	60	6.5	4	19	146	79.5	168	40	9.5	6	23
3 1/2	159	92	178	45	6.5	4	19	162	92	184	45	9.5	6	23
4	171	108	191	50	6.5	4	19	178	108	200	50	12.5	8	23
5	193	133.5	216	55	9.5	6	22	212	133.5	235	60	12.5	8	23
6	219	159	241	60	9.5	6	22	247	159	270	45	16	8	23
8	276	209.5	298	70	12.5	8	22	305	209.5	330	55	19	10	23
10	336	260.5	362	65	16	8	26	359	260.5	387	45	25.5	14	23
12	406	305	432	70	22.5	10	26	419	305	451	50	28.5	18	23
14	441	336.5	476	70	25.5	14	29	476	336.5	514	45	32	20	23
16	505	387.5	540	70	25.5	14	29	530	387.5	572	50	36.5	22	23
18	540	438	578	70	25.5	14	32	587	438	629	45	41.5	24	23
20	597	489	635	65	28.5	18	32	645	489	686	50	44.5	24	23
22	657	546	692	65	35	20	35	702	546	743	50	44.5	24	23
24	708	590.5	750	75	35	20	35	765	590.5	813	60	54	40	23
26	762	641.5	806	70	51	32	35	822	641.5	876	50	73	60	23
28	828	692	864	60	51	32	35	895	692	940	60	73	60	23
30	870	743	914	65	54	34	35	940	743	997	60	85	70	23
32	936	794	978	65	54	34	41	1003	794	1054	65	85	70	23
34	978	844.5	1029	55	57	34	41	1044	844.5	1105	70	98	80	23
36	1035	895.5	1086	60	57	34	41	1105	895.5	1168	55	98	80	23

DN	400lbs							600lbs						
	B	d	C	E	b1	b2	F	B	d	C	E	b1	b2	F
1/2	51	16	67	30	6.5	4	16	51	16	67	30	6.5	4	16
3/4	63	22	83	35	6.5	4	16	63	22	83	35	6.5	4	16
1	70	28.5	89	40	9.5	6	19	70	28.5	89	40	9.5	6	19
1 1/4	79	35	98	45	9.5	6	19	79	35	98	50	9.5	6	19
1 1/2	92	41.5	114	55	9.5	6	23	92	41.5	114	55	9.5	6	23
2	108	54	127	28	9.5	6	16	108	54	127	28	9.5	6	16
2 1/2	127	63.5	149	35	9.5	6	23	127	63.5	149	35	12.5	8	23
3	146	79.5	168	40	12.5	8	23	146	79.5	168	40	16	10	23
3 1/2	159	92	184	45	12.5	8	23	159	92	184	45	16	10	23
4	174	105	200	50	16	10	23	190	105	216	55	16	10	23
5	209	130	235	60	16	10	23	238	130	267	70	22.5	14	23
6	244	155.5	270	45	19	12	23	263	155.5	292	45	25.5	16	23
8	301	203	330	55	22.5	14	23	317	203	349	55	32	20	23
10	355	257	387	45	28.5	16	23	390	257	432	45	38	24	23
12	416	305	451	50	38	24	23	454	305	489	40	44.5	30	23
14	479	336.5	514	45	41.5	26	23	489	336.5	527	40	51	36	23
16	533	387.5	572	50	47.5	30	23	562	387.5	603	50	57	40	23
18	590	438	629	45	57	40	23	609	438	654	55	63	50	23
20	644	489	686	50	57	40	23	679	489	724	50	70	64	23
22	698	540	743	50	70	55	23	730	540	778	55	70	64	23
24	765	590.5	813	60	70	55	23	787	590.5	838	55	82	68	23
26	819	641.5	876	50	85	70	23	851	641.5	915	50	101	85	23
28	889	692.2	783	60	85	70	23	911	692.2	965	55	101	85	23
30	930	743	997	60	98	80	23	959	743	1022	60	110	90	23
32	1000	794	918	65	98	80	23	1119	794	1080	60	110	90	23
34	1041	844.5	1105	70	105	90	23	1060	844.5	1130	65	117	100	23
36	1105	895.5	1168	55	110	95	23	1117	895.5	1194	65	124	110	23

NOTE 1. Preferably one piece except for stainless and allied steels, which can be manufactured in 3 pieces.
 2. Dimension of other standards available on request.

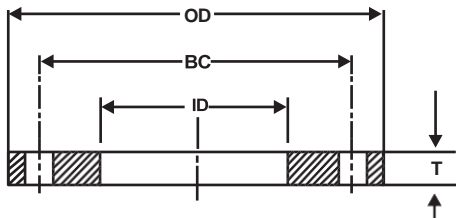

AWWA C207-07, CLASS B, SLIP ON & BLIND

Dimensions in Inches

Nominal Size	Outside Ø (OD)	Slip-on Bore (ID)	No. of Bolt Holes	Ø of Holes	Ø Bolt Circle (BC)	Thickness (T)		Weight (lbs)	
						Slip-on	Blind	Slip-on	Blind
4	9.00	4.57	8	0.750	7.50	0.938	1.312	5.312	13
5	10.00	5.66	8	0.875	8.50	0.938	1.438	6.438	-
6	11.00	6.72	8	0.875	9.50	1.000	1.562	7.562	19
8	13.50	8.72	8	0.875	11.75	1.125	1.750	9.688	30
10	16.00	10.88	12	1.000	14.25	1.188	1.938	12.000	43
12	19.00	12.88	12	1.000	17.00	1.250	2.188	14.375	64
14	21.00	14.19	12	1.125	18.75	1.375	2.250	15.750	85
16	23.50	16.19	16	1.125	21.25	1.438	2.500	18.000	93
18	25.00	18.19	16	1.250	22.75	1.562	2.688	19.875	120
20	27.50	20.19	20	1.250	25.00	1.688	2.875	22.000	155
22	29.50	22.19	20	1.375	27.25	1.812	3.125	24.250	-
24	32.00	24.19	20	1.375	29.50	1.875	3.250	26.125	210
26	34.25	26.19	24	1.375	31.75	2.000	3.375	28.500	-
28	36.50	28.19	28	1.375	34.00	2.062	3.438	30.750	-
30	38.75	30.19	28	1.375	36.00	2.125	3.500	32.750	305
32	41.75	32.19	28	1.625	38.50	2.250	3.625	35.000	-
36	46.00	36.19	32	1.625	42.75	2.375	3.750	39.250	450
38	48.75	38.19	32	1.625	45.25	2.375	3.750	41.750	-
40	50.75	40.19	36	1.625	47.25	2.500	3.875	43.750	-
42	53.00	42.19	36	1.625	49.50	2.625	4.000	46.000	605
44	55.25	44.19	40	1.625	51.75	2.625	4.000	48.000	-
48	59.50	48.19	44	1.625	56.00	2.750	4.125	52.250	800
54	66.25	54.19	44	1.875	62.75	3.000	4.375	58.750	1025
60	73.00	60.19	52	1.875	69.25	3.125	4.500	65.250	1250
66	80.00	66.19	52	1.875	76.00	3.375	4.875	71.500	-
72	86.50	72.19	60	1.875	82.50	3.500	5.000	78.500	1925
78	93.00	78.19	64	2.125	89.00	3.875	5.375	84.500	-
84	99.75	84.19	64	2.125	95.50	3.875	5.375	90.500	2600
90	106.50	90.19	68	2.438	102.00	4.250	5.750	96.750	-
96	113.25	96.19	68	2.438	108.50	4.250	5.750	102.750	3275

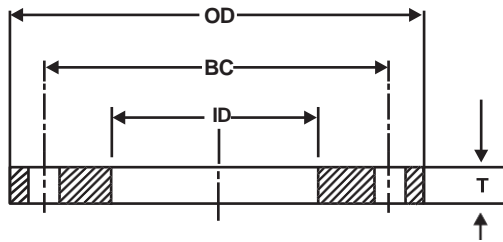

AWWA C207-07, CLASS D, SLIP ON & BLIND

Dimensions in Inches

Nominal Size	Outside ϕ (OD)	Slip-on Bore (ID)	No. of Bolt Holes	ϕ of Holes	ϕ Bolt Circle (BC)	Thickness (T)		Weight (lbs)	
						Slip-on	Blind	Slip-on	Blind
2	6.00	2.44	4	0.750	4.75	0.625	0.625	3.90	4.7
2.5	7.00	2.94	4	0.750	5.50	0.625	0.625	5.30	6.5
3	7.50	3.57	4	0.750	6.00	0.625	0.625	5.70	7.5
4	9.00	4.57	8	0.750	7.50	0.625	0.625	7.70	10.6
5	10.00	5.66	8	0.875	8.50	0.625	0.650	8.80	13.6
6	11.00	6.72	8	0.875	9.50	0.688	0.693	10.70	17.7
8	13.50	8.72	8	0.875	11.75	0.688	0.812	15.30	31.8
10	16.00	10.88	12	1.000	14.25	0.688	0.953	19.20	51.7
12	19.00	12.88	12	1.000	17.00	0.812	1.117	33.10	86.7
14	21.00	14.19	12	1.125	18.75	0.938	1.133	46.90	107.4
16	23.50	16.19	16	1.125	21.25	1.000	1.265	60.10	149.8
18	25.00	18.19	16	1.250	22.75	1.062	1.331	63.60	177.7
20	27.50	20.19	20	1.250	25.00	1.125	1.448	79.40	233.6
22	29.50	22.19	20	1.375	27.25	1.188	1.568	89.90	290.5
24	32.00	24.19	20	1.375	29.50	1.250	1.661	113.40	364.5
26	34.25	26.25	24	1.375	31.75	1.312	1.786	128.00	448.2
28	36.50	28.25	28	1.375	34.00	1.312	1.906	140.50	542.6
30	38.75	30.25	28	1.375	36.00	1.375	2.008	163.30	647.3
32	41.75	32.25	28	1.625	38.50	1.500	2.150	210.10	798.6
34	43.75	34.25	32	1.625	40.50	1.500	2.252	219.10	916.9
36	46.00	36.25	32	1.625	42.75	1.625	2.370	259.40	1071.4
38	48.75	38.25	32	1.625	45.25	1.625	2.506	299.80	1278.2
40	50.75	40.25	36	1.625	47.25	1.625	2.609	311.10	1440.1
42	53.00	42.25	36	1.625	49.50	1.750	2.729	361.70	1648.1
44	55.25	44.25	40	1.625	51.75	1.750	2.849	385.00	1868.3
48	59.50	48.25	44	1.625	56.00	1.875	3.072	457.30	2340.7
54	66.25	54.25	44	1.875	62.75	2.125	3.435	610.60	3236.7
60	73.00	60.25	52	1.875	69.25	2.250	3.779	759.10	4327.6
66	80.00	66.25	52	1.875	76.00	2.500	4.136	1017.00	5722.2
72	86.50	72.25	60	1.875	82.50	2.625	4.480	1198.20	7249.0
78	93.00	78.25	64	2.125	89.00	2.750	-	1368.90	-
84	99.75	84.25	64	2.125	95.50	2.875	-	1639.70	-
90	106.50	90.25	68	2.438	102.00	3.000	-	1878.30	-
96	113.25	96.25	68	2.438	108.50	3.250	-	2298.30	-

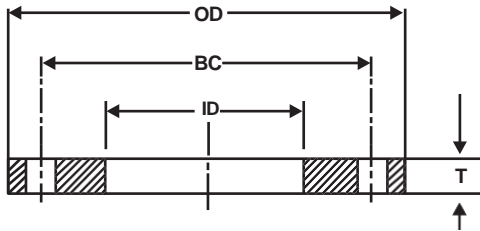

AWWA C207-07, CLASS E, SLIP ON & BLIND

Dimensions in Inches

Nominal Size	Outside \varnothing (OD)	Slip-on Bore (ID)	No. of Bolt Holes	\varnothing of Holes	\varnothing Bolt Circle (BC)	Thickness (T)		Weight (lbs)	
						Slip-on	Blind	Slip-on	Blind
4	9.00	4.57	8	0.750	7.50	1.125	1.125	13.90	19.2
5	10.00	5.66	8	0.875	8.50	1.188	1.188	16.30	24.8
6	11.00	6.72	8	0.875	9.50	1.313	1.313	20.40	33.6
8	13.50	8.72	8	0.875	11.75	1.500	1.500	33.40	60.8
10	16.00	10.88	12	1.000	14.25	1.563	1.563	43.70	84.9
12	19.00	12.88	12	1.000	17.00	1.750	1.750	71.30	135.9
14	21.00	14.19	12	1.125	18.75	1.875	1.875	93.70	177.7
16	23.50	16.19	16	1.125	21.25	2.000	2.000	120.10	236.8
18	25.00	18.19	16	1.250	22.75	2.125	2.125	127.30	283.7
20	27.50	20.19	20	1.250	25.00	2.375	2.375	167.70	383.2
24	32.00	24.19	20	1.375	29.50	2.625	2.625	234.30	576.1
26	34.25		24	1.375	31.75	2.750	2.750		690.1
28	36.50		28	1.375	34.00	2.750	2.750		782.9
30	38.75		28	1.375	36.00	2.875	2.875		926.8
36	46.00		32	1.625	42.75	3.125	3.209		1450.7
38	48.75		32	1.625	45.25	3.125	3.394		1731.1
40	50.75		36	1.625	47.25	3.250	3.533		1950.2
42	53.00		36	1.625	49.50	3.375	3.695		2231.5
44	55.25		40	1.625	51.75	3.375	3.857		2529.4
48	59.50		44	1.625	56.00	3.500	4.159		3169.0
54	66.25		44	1.875	62.75	3.750	4.651		4382.5
60	73.00		52	1.875	69.25	3.875	5.116		5858.7
66	80.00		52	1.875	76.00	4.250	5.601		7749.0
72	86.50		60	1.875	82.50	4.375	6.066		9815.3
78	93.00		64	2.125	89.00	4.750			
84	99.75		64	2.125	95.50	4.750			
90	106.50		68	2.438	102.00	5.125			
96	113.25		68	2.438	108.50	5.125			

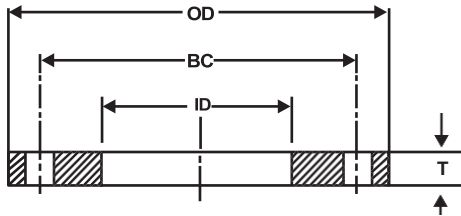

AWWA C207-07, CLASS F, SLIP ON & BLIND

Dimensions in Inches

Nominal Size	Outside ϕ (OD)	Slip-on Bore (ID)	No. of Bolt Holes	ϕ of Holes	ϕ Bolt Circle (BC)	Thickness (T)		Weight (lbs)	
						Slip-on	Blind	Slip-on	Blind
4	10.00	4.57	8	0.875	7.88	1.130	1.130	18.30	23.6
5	11.00	5.66	8	0.875	9.25	1.210	1.210	22.30	30.9
6	12.50	6.73	12	0.875	10.63	1.310	1.310	29.70	42.9
8	15.00	8.73	12	1.000	13.00	1.310	1.310	39.90	62.1
10	17.50	10.88	16	1.125	15.25	1.500	1.500	56.00	95.5
12	20.50	12.88	16	1.250	17.75	1.630	1.630	83.20	143.4
14	23.00	14.19	20	1.250	20.25	1.940	1.940	127.90	214.9
16	25.50	16.19	20	1.375	22.50	2.140	2.140	166.80	291.7
18	28.00	18.19	24	1.375	24.75	2.250	2.250	204.20	369.8
20	30.50	20.19	24	1.375	27.00	2.330	2.330	247.40	458.8
22	33.00	22.19	24	1.375	29.25	2.500	2.500	306.70	580.6
24	36.00	24.19	24	1.625	32.00	2.690	2.690	387.60	737.9
26	38.25		28	1.875	34.50	3.000	3.000		911.0
28	40.75		28	1.875	37.00	3.130	3.130		1088.0
30	43.00		28	1.875	39.25	3.150	3.166		1233.3
32	45.25		28	1.875	41.50	3.250	3.332		1445.2
34	47.50		28	1.875	43.50	3.380	3.475		1668.6
36	50.00		32	2.125	46.00	3.460	3.671		1924.2
38	52.25		32	2.125	48.00	3.500	3.815		2195.0
40	54.25		36	2.125	50.25	3.630	3.982		2463.8
42	57.00		36	2.125	52.75	3.810	4.171		2864.7
44	59.25		36	2.125	55.00	4.000	4.338		3231.9
46	61.50		40	2.125	57.25	4.130	4.505		3610.6
48	65.00		40	2.125	60.75	4.500	4.781		4302.9



6BAR

DIN 2573 SLIP - ON

FLANGES DIN 2527 BLIND

FLANGES

DIN 2631 WELDING NECK

FLANGES

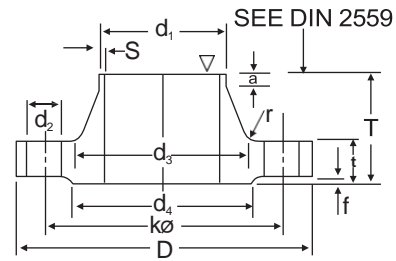

WELDING NECK

Unit : mm

Bore		Common Dimension						Hub				Raise Face		Drilling			Approx Weight (kg)		
Nominal Bore	d ₁	D	t			K	T	d ₃	s	r	a ≈	d ₄	f	No. of Bolt	Dia. of Bolt		d ₂	DIN 2573	DIN 2631
			Welding neck	slip-on	Blind														
10	14 17.2*)	75	12	12	12	50	28	22 26	1.8	4	6	35	2	4	M10	-	11.5	0.036	0.335
15	20 21.3*)	80	12	12	12	55	30	28 30	2.0	4	6	40	2	4	M10	-	11.5	0.410	0.392
20	25 26.9*)	90	14	14	14	65	32	35 38	2.3	4	6	50	2	4	M10	-	11.5	0.600	0.592
25	30 33.7*)	100	14	14	14	75	35	40 42	2.6	4	6	60	2	4	M10	-	11.5	0.740	0.747
32	38 42.4*)	120	14	16	14	90	35	50 55	2.6	6	6	70	2	4	M12 (1/2")		14	1.19	1.05
40	44.5 48.3*)	130	14	16	14	100	38	58 62	2.6	6	7	80	3	4	M12 (1/2")		14	1.39	1.18
50	57 60.3*)	140	14	16	14	110	38	70 74	2.9	6	8	90	3	4	M12 (1/2")		14	1.53	1.34
65	76.1*)	160	14	16	14	130	38	88	2.9	6	9	110	3	4	M12 (1/2")		14	1.89	1.67
80	88.9*)	190	16	18	16	150	42	102	3.2	8	10	128	3	4	M16 (5/8")		18	2.98	2.71
100	108 114.3*)	210	16	18	16	170	45	122 130	3.6	8	10	148	3	4	M16 (5/8")		18	3.46	3.24
125	133 139.7*)	240	18	20	18	200	48	148 155	4.0	8	10	178	3	8	M16 (5/8")		18	4.60	4.49
150	159 168.3*)	265	18	20	18	225	48	172 184	4.5	10	12	202	3	8	M16 (5/8")		18	5.22	5.15
200	216 219.1*)	320	20	22	20	280	55	230 236	5.9	10	15	258	3	8	M16 (5/8")		18	7.15	7.78
250	267 273*)	375	22	24	22	335	60	282 290	6.2	12	15	312	3	12	M16 (5/8")		18	9.61	10.8
300	381 323.9*)	440	22	24	22	395	62	335 342	7.1	12	15	365	4	12	M20 (3/4")		23	12.6	14.0
350	355.6*)	490	22	26	22	445	62	385	7.1	12	15	415	4	12	M20 (3/4")		23	15.6	16.1
400	368 406.4*)	540	22	28	22	495	65	438	7.1	12	15	455	4	16	M20 (3/4")		23	18.4	18.3
500	418 508*) 521	645	24	30	24	600	68	538	7.1	12	15	570	4	20	M20 (3/4")		23	24.5	24.6

Out side diameter of pipe complies with ISO

600	609.6*) 622	755	24			705	70	640	7.1	12	16	670	5	20	M24	(7/8")	27		
700	711.2*) 720	860	24			810	70	740	7.1	12	16	775	5	24	M24	(7/8")	27		
800	812.8*) 820	975	24			920	70	842	7.1	12	16	880	5	24	M27	(1")	30		
900	914.4*) 920	1075	26			1020	70	942	7.1	12	16	980	5	24	M27	(1")	30		
1000	1016*) 1020	1175	26			1120	70	1045	7.1	16	16	1080	5	28	M27	(1")	30		

Out side diameter of pipe complies with



10BAR

DIN 2576 SLIP - ON FLANGES

DIN 2527 BLIND FLANGES

DIN 2632 WELDING NECK FLANGES

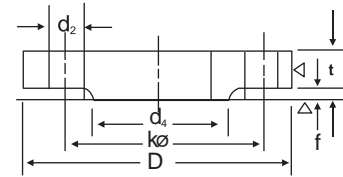
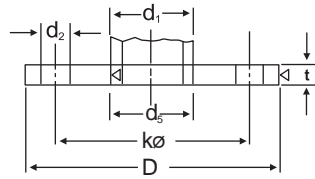

SLIP-ON

BLIND

Unit : mm

Bore		Common Dimension						Hub				Raise Face		Drilling			Approx Weight (kg)		
Nomin al Bore	d ₁	D	t			K	T	d ₃	s	r	a ~	d ₄	f	No. of Bol t	Dia. of Bolt		d ₂	DIN 2576	DIN 2632
			Weld- ing neck	slip - on	Blind														
10	14 17.2*)	90	14	14	14	60	35	25 28	1.8	4	6	40	2	4	M12	(1.2")	14	0.163	0.580
15	20 21.3*)	95	14	14	14	65	35	30 32	2.0	4	6	45	2	4	M12	(1.2")	14	0.675	0.648
20	25 26.9*)	105	16	16	16	75	38	38 40	2.3	4	6	58	2	4	M12	(1.2")	14	0.947	0.952
25	30 33.7*)	115	16	16	16	85	38	42 45	2.6	4	6	68	2	4	M12	(1.2")	14	1.14	1.14
32	38 42.4*)	140	16	16	16	100	40	52 56	2.6	6	6	78	2	4	M16	(5/8")	18	1.66	1.69
40	44.5 48.3*)	150	16	16	18	110	42	60 64	2.6	6	7	88	3	4	M16	(5/8")	18	1.89	1.86
50	57 60.3*)	165	18	18	18	125	45	72 75	2.9	6	8	102	3	4	M16	(5/8")	18	2.51	2.53
65	76.1*)	185	18	18	18	145	45	90	2.9	6	10	122	3	4	M16	(5/8")	18	3.00	3.06
80	88.9*)	200	20	20	20	160	50	105	3.2	8	10	138	3	4	M16	(5/8")	18	3.79	3.70
100	108 114.3*)	220	20	20	20	180	52	125 131	3.6	8	12	158	3	8	M16	(5/8")	18	4.20	4.62
125	133 139.7*)	250	22	22	22	210	55	150 156	4.0	8	12	188	3	8	M16	(5/8")	18	5.71	6.30
150	159 168.3*)	285	22	22	22	240	55	175 184	4.5	10	12	212	3	8	M20	(3/4")	23	6.72	7.75
200	216 219.1*)	340	24	24	24	295	62	232 235	5.9	10	16	268	3	8	M20	(3/4")	23	9.50	11.3
250	267 273*)	395	26	26	26	350	68	285 292	6.3	12	16	320	3	12	M20	(3/4")	23	12.5	14.7
300	381 323.9*)	445	26	26	28	400	68	335 344	7.1	12	16	370	4	12	M20	(3/4")	23	14.4	17.6
350	355.6*) 368	505	26	28	30	460	68	385	7.1	12	16	430	4	16	M20	(3/4")	23	20.6	21.4
400	406.4*) 419	565	26	32	32	515	72	440	7.1	12	16	482	4	16	M24	(7/8")	27	27.9	26.1
500	508*) 521	670	28	38	34	620	75	542	7.1	12	16	585	4	20	M24	(7/8")	27	41.1	34.7
600	609.6*) 622	780	28			725	80	642	7.1	12	18	685	5	20	M27	(1")	30		
700	711.2*) 720	895	30			840	80	754	8.0	12	18	800	5	24	M27	(1")	30		
800	812.8*) 820	1015	32			950	90	850	8.0	12	18	905	5	24	M30	(1.1/8")	30		

900	914.4*) 920	1115	34			1050	95	950	10.0	12	20	1005	5	28	M30	(1.1/8"))	33		
1000	1016*) 1020	1230	34			1160	95	1052	10.0	16	20	1110	5	28	M33	(1 1/4")	36		

Out side diameter of pipe complies with



16BAR

DIN 2543 SLIP - ON FLANGES

DIN 2527 BLIND FLANGES

DIN 2633 WELDING NECK FLANGES

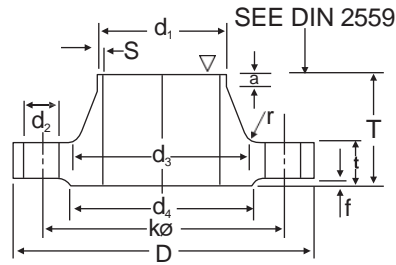

WELDING NECK

Unit : mm

Bore		Common Dimension						Hub				Raise Face		Drilling			Approx Weight (kg)		
Nomin al Bore	d ₁	D	t			K	T	d ₃	s	r	a ≈	d ₄	f	No. of Bol t	Dia. of Bolt		d ₂	DIN 2543	DIN 2633
			Weld- ing neck	slip-on (No-hub)	Blind														
10	14 17.2*)	90	14	14	14	60	35	25 28	1.8	4	6	40	2	4	M12	(1.2")	14	0.63	0.580
15	20 21.3*)	95	14	14	14	65	35	30 32	2.0	4	6	45	2	4	M12	(1.2")	14	0.72	0.648
20	25 26.9*)	105	16	16	16	75	38	38 40	2.3	4	6	58	2	4	M12	(1.2")	14	1.01	0.952
25	30 33.7*)	115	16	16	16	85	38	42 45	2.6	4	6	68	2	4	M12	(1.2")	14	1.23	1.14
32	38 42.4*)	140	16	16	16	100	40	52 56	2.6	6	6	78	2	4	M16	(5/8")	18	1.80	1.69
40	44.5 48.3*)	150	16	16	16	110	42	60 64	2.6	6	7	88	3	4	M16	(5/8")	18	2.09	1.86
50	57 60.3*)	165	18	18	18	125	45	72 75	2.9	6	8	102	3	4	M16	(5/8")	18	2.88	2.53
65	76.1*)	185	18	18	18	145	45	90	2.9	6	10	122	3	4	M16	(5/8")	18	3.66	3.06
80	88.9*)	200	20	20	20	160	50	105	3.2	8	10	138	3	8	M16	(5/8")	18	4.77	3.70
100	108 114.3*)	220	20	20	20	180	52	125 131	3.6	8	12	158	3	8	M16	(5/8")	18	5.65	4.62
125	133 139.7*)	250	22	22	22	210	55	150 156	4.0	8	12	188	3	8	M16	(5/8")	18	8.42	6.30
150	159 168.3*)	285	22	22	22	240	55	175 184	4.5	10	12	212	3	8	M20	(3/4")	23	10.4	7.75
200	216 219.1*)	340	24	24	24	295	62	232 235	5.9	10	16	268	3	12	M20	(3/4")	23	16.1	11.0
250	267 273*)	405	26	26	26	355	70	285 292	6.3	12	16	320	3	12	M24	(7/8")	27	24.9	15.6
300	381 323.9*)	460	28	28	28	410	78	338 344	7.1	12	16	378	4	12	M24	(7/8")	27	35.1	22.0
350	355.6*)	520	30	30	30	470	82	390	8.0	12	16	438	4	16	M24	(7/8")	27	47.8	28.7
400	406.4*)	580	32	32	32	525	85	445	8.8	12	16	490	4	16	M27	(1")	30	63.5	36.3
500	419 508*) 521	715	34	36	34	650	90	548	8.0	12	16	610	4	20	M30	(1 1/8")	33	102.0	59.3
600	609.6*) 622	840	36	40		770	95	652	8.8	12	18	725	5	20	M33	(1 1/4")	36		
700	711.2*) 720	910	36			840	100	755	8.8	12	18	795	5	24	M33	(1 1/4")	36		

Out side diameter of pipe complies with ISO

800	812.8*) 820	102 5	38			950	105	855	10.0	12	20	900	5	24	M36	(1 3/8")	39		
900	914.4*) 920	112 5	40			1050	110	955	10.0	12	20	1000	5	28	M36	(1 3/8")	39		
1000	1016*) 1020	125 5	42			1170	120	1058	10.0	16	20	1115	5	28	M39	(1 1/2")	42		

Out side diameter of pipe complies with



25BAR

DIN 2544 SLIP - ON FLANGES

DIN 2527 BLIND FLANGES

DIN 2634 WELDING NECK FLANGES

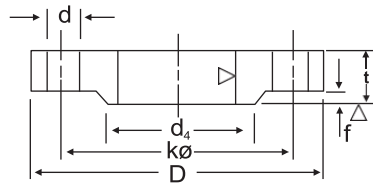

SLIP-ON

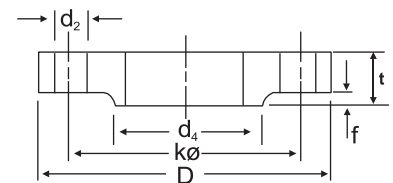

BLIND

Unit : mm

Bore		Common Dimension					Hub				Raise Face		Drilling			Approx Weight (kg)			
Nominal Bore	d ₁	D	t			K	T	d ₃	s	r	a ≈	d ₄	f	No. of Bolt	Dia. of Bolt		d ₂	DIN 2544	DIN 2634
			Welding neck	slip-on (No-hub)	Blind														
10	14 17.2*)	90	16	16	16	60	35	25 28	1.8	4	6	40	2	4	M12	(1.2")	14	0.72	0.661
15	20 21.3*)	95	16	16	16	65	35	30 32	2.0	4	6	45	2	4	M12	(1.2")	14	0.81	0.746
20	25 26.9*)	105	18	18	18	75	40	38 40	2.3	4	6	58	2	4	M12	(1.2")	14	1.24	1.06
25	30 33.7*)	115	18	18	18	85	40	42 46	2.6	4	6	68	2	4	M12	(1.2")	14	1.38	1.29
32	38 42.4*)	140	18	18	18	100	42	52 56	2.6	6	6	78	2	4	M16	(5/8")	18	2.03	1.88
40	44.5 48.3*)	150	18	18	18	110	45	60 64	2.6	6	7	88	3	4	M16	(5/8")	18	2.35	2.34
50	57 60.3*)	165	20	20	20	125	48	72 75	2.9	6	8	102	3	4	M16	(5/8")	18	3.20	2.82
65	76.1*)	185	22	22	22	145	52	90	2.9	6	10	122	3	8	M16	(5/8")	18	4.29	3.74
80	88.9*)	200	24	24	24	160	58	105	3.2	8	12	138	3	8	M16	(5/8")	18	5.88	4.75
100	108 114.3*)	235	24	24	24	190	65	128 134	3.6	8	12	162	3	8	M20	(3/4")	23	7.54	6.52
125	133 139.7*)	270	26	26	26	220	68	155 162	4.0	8	12	188	3	8	M24	(7/8")	27	10.8	9.07
150	159 168.3*)	300	28	28	28	250	75	182 192	4.5	10	12	218	3	8	M24	(7/8")	27	14.5	11.8
200	216 219.1*)	360	30	30	30	310	80	240 244	6.3	10	16	278	3	12	M24	(7/8")	27	22.3	17.0
250	267 273*)	425	32	32	32	370	88	292 298	7.1	12	18	355	3	12	M27	(1")	30	33.5	24.4
300	381 323.9*)	485	34	34	34	430	92	345 352	8.0	12	18	395	4	16	M27	(1")	30	46.3	31.2
350	355.6*)	555	38	38	38	490	100	398	8.0	12	20	450	4	16	M30	(1 1/8")	33	68.0	45.0
400	368 406.4*)	620	40	40	40	550	110	452	8.8	12	20	505	4	16	M33	(1 1/4")	36	89.7	58.7
500	508*)	730	44	44	44	660	125	558	10.0	12	20	615	4	20	M33	(1 1/4")	36	138.0	86.1
600	609.6*)	845	46			770	125	660	11.0	12	20	720	5	20	M36	(1 3/8")	39		101.0

700	711.2*) 720	960	46			875	125	760	12.5	12	20	820	5	24	M39	(1 1/2")	42		134.0
800	812.8*) 820	1085	50			990	135	865	14.2	12	22	930	5	24	M45	(1 3/4")	48		183.0
900	914.4*) 920	1185	54			1090	145	968	16.0	12	24	1030	5	28	M45	(1 3/4")	48		232.0
1000	1016*) 1020	1320	58			1210	155	1070	17.5	16	24	1140	5	28	M52	(2")	56		302.0



DIMENSIONAL TOLERANCES OF FORGED FLANGES ANSI B 16.5

**Threaded, Slipon, Lapjoint,
Socket Welding & Blind**

Welding Neck

Outside Diameter	O.D. is 600 or smaller O. D over 600	± 1.6 ± 3.1	Outside Diameter	O.D. is 50 or smaller O. D over 600	± 1.6 ± 3.1
Inside Diameter (bore)	250 and smaller 12 through 450 500 and larger	± 0.7 ± 1.6 ± 3.1 -1.6	Inside Diameter slip lap joint:	threaded: to standard gauge limits socket-welding: 250 and larger 300 and larger	(bore) $+0.7$ -0.0 $+1.6$ -0.0
Diameter of contact face	1.6 raise face 6.3 raised face: tongue & grooved male & female	± 0.7 ± 0.4	Diameter of counter bore	threaded 250 and smaller 300 and larger	$+0.7$ -0.0 $+1.6$ -0.0
Diameter of hub at base	When E is 600 or smaller When E is over 600	± 1.6 ± 3.1	Outside diameter hub	300 and smaller 350 and larger	$+2.3$ -1.6 ± 3.1
Diameter hub at point of welding	125 and smaller 150 and larger	$+0.7$ ± 0.7 $+4.0$ ± 0.0	Diameter of contact face	1.6 raised face 6.3 raised: tongue & grooved	± 0.7
Thickness	450 and smaller 500 and larger	$+3.1$ ± 0.0 $+4.7$ ± 0.0	Thickness	450 and smaller 500 and larger	$+3.1$ -0.0 $+4.7$ -0.0
Length through			Length through		
Drilling	bolt circle bolt hole spacing	± 1.6 ± 0.7	Drilling	bolt circle bolt hole spacing	± 1.6 ± 0.7

WELDING NECK FLANGE BORE

NPS (NB)	O.D. (MM)	Sch. 10	Sch. 20	Sch. 30	Sch. Std	Sch. 40	Sch. XS	Sch. 80	Sch. 120	Sch. 160	Sch. XXS
15	21.33	17.1	-	-	15.7	15.7	13.8	13.8	-	11.7	6.4
25	33.40	27.9	-	-	26.6	25.4	24.3	24.3	-	20.7	15.2
40	48.26	42.7	-	-	40.8	40.8	38.1	38.1	-	33.7	27.9
65	73.02	66.9	-	-	62.4	62.4	59.0	59.0	-	53.9	44.9
100	114.30	108.2	-	-	102.2	102.2	97.1	97.1	92.0	87.3	80.0
150	168.27	161.5	-	-	154.0	154.0	146.3	146.3	139.7	131.7	124.3
250	273.05	264.7	260.3	257.4	254.5	254.5	247.6	242.8	230.1	215.9	222.2
350	355.60	346.2	337.8	336.5	336.5	333.3	330.2	317.5	300.0	284.1	-
450	457.20	447.5	441.1	434.9	438.1	428.6	431.8	409.5	387.3	366.7	-
600	609.60	596.9	590.5	581.0	590.5	574.6	584.2	547.6	517.5	490.5	-



ANSI FLANGES WEIGHT (KGS)

Nom Pipe Size	150#			300#			600#			900#			1500#			2500#		
	WN	S/O	B/K	WN	S/O	B/K	WN	S/O	B/K	WN	S/O	B/K	WN	S/O	B/K	WN	S/O	B/K
1/2"	0.7	0.4	0.5	0.8	0.7	0.8	0.9	0.8	0.8	2.1	1.8	1.9	2.1	1.8	1.9	3.2	3	3
3/4"	0.8	0.7	0.8	1.4	1.2	1.2	1.6	1.4	1.4	2.7	2.4	2.7	2.7	2.4	2.7	3.6	4	4.5
1"	1.1	0.8	0.9	1.7	1.4	1.5	1.9	1.7	1.7	3.9	3.6	3.7	3.9	3.6	3.7	5.4	5	5
1.1/4"	1.5	1.2	1.3	2.2	1.8	2	2.6	2.1	2.4	4.5	4.1	4.3	4.5	4.1	4.3	7.8	8	8
1.1/2"	1.8	1.4	1.6	3.2	2.7	2.9	3.6	3.1	3.4	6.2	5.4	5.9	6.2	5.4	5.9	11.5	11	11
2"	2.7	2.2	2.6	3.6	3.2	3.5	4.7	3.9	4.4	11.3	10.5	11.3	11.3	10.5	11.3	19	17	17
2.1/2"	4.4	3.5	4.1	5.4	4.5	5.3	4.8	5.4	6.8	16.3	15.8	16	16.3	15.8	16	24	25	25
3"	5.2	3.8	5.1	7.3	5.9	7.2	8.7	7.3	8.9	15	12.3	16.8	21	21.5	19.5	42.6	38	39
3.1/2"	6.4	5	6.5	8.9	7.5	9.2	11.6	9	12.7	-	-	-	-	-	-	-	-	-
4"	7.5	5.6	7.5	11.8	10	12.2	18.4	16.5	18.6	24	23.2	24.5	31.8	31	33	64	58	60
5"	9.2	6.5	9.2	16	12.5	16	31	28.5	30.8	38.5	37.5	39.5	59	58.8	60	111	95	101
6"	11.0	8.1	11.8	20.2	16.5	22	37	36.2	38	50	48.3	51.5	72	74	75	171	146	156
8"	18.4	13	20.4	31.2	25.5	36	54.5	51.5	62.2	85	75	89	124	112	125	261	220	242
10"	25.5	18.4	31	44.3	35	55	98.5	76.2	102	123	110	131	207	184	215	485	420	465
12"	37	28.5	47	63.5	52	82.5	105	89.5	132	168	146	187	306	264	316	698	590	665
14"	51	37.5	60	86	73	108	150	102	158	198	172	224	416	-	-	-	-	-
16"	61.5	44.5	61	112	88	139	177	150	225	225	192	259	567	-	-	-	-	-
18"	71.5	54	93	141	115	178	228	180	285	318	272	383	736	-	-	-	-	-
20"	85	72	127	173	139	228	285	231	365	376	330	482	929	-	-	-	-	-
24"	119	95	190	248	212	350	372	330	532	680	632	905	1504	-	-	-	-	-



Bolt and Stud Dimensions ASME B 16.5

Nominal Pipe Size	150 LB. Flanges				300 LB. Flanges				600 LB. Flanges			
	# Bolts or Studs	Dia of Bolts or Studs	Length of Stud		# Bolts or Studs	Dia of Bolts or Studs	Length of Stud		# Bolts or Studs	Dia of Bolts or Studs	Length of Stud	
			1/16 RF	RTJ			1/16 RF	RTJ			1/4 RF	RTJ
1/2	4	0.50	2-1/4	-	4	0.50	2 1/2	3	4	0.50	3	3
3/4	4	0.50	2-1/2	-	4	0.63	3	3-1/2	4	0.63	3-1/2	3-1/2
1	4	0.50	2-1/2	3	4	0.63	3	3-1/2	4	0.63	3-1/2	3-1/2
1-1/4	4	0.50	2-3/4	3-1/4	4	0.63	3-1/4	3-3/4	4	0.63	3-3/4	3-3/4
1-1/2	4	0.50	2-3/4	3-1/4	4	0.75	3-1/2	4	4	0.75	4-1/4	4-1/4
2	4	0.63	3-1/4	3-3/4	8	0.63	3-1/2	4	8	0.63	4-1/4	4-1/4
2-1/2	4	0.63	3-1/2	4	8	0.75	4	4-1/2	8	0.75	4-3/4	4-3/4
3	4	0.63	3-1/2	4	8	0.75	4-1/4	4-3/4	8	0.75	5	5
3-1/2	8	0.63	3-1/2	4	8	0.75	4-1/4	5	8	0.88	5-1/2	5-1/2
4	8	0.63	3-1/2	4	8	0.75	4-1/2	5	8	0.88	5-3/4	5-3/4
5	8	0.75	3-3/4	4-1/4	8	0.75	4-3/4	5-1/4	8	1.00	6-1/2	6-1/2
6	8	0.75	4	4-1/2	12	0.75	4-3/4	5-1/2	12	1.00	6-3/4	6-3/4
8	8	0.75	4-1/4	4-3/4	12	0.88	5-1/2	6	12	1.13	7-1/2	7-3/4
10	12	0.88	4-1/2	5	16	1.00	6-1/4	6-3/4	16	1.25	8-1/2	8-1/2
12	12	0.88	4-3/4	5-1/4	16	1.13	6-3/4	7-1/4	20	1.25	8-3/4	8-3/4
14	12	1.00	5-1/4	5-3/4	20	1.13	7	7-1/2	20	1.38	9-1/4	9-1/4
16	16	1.00	5-1/4	5-3/4	20	1.25	7-1/2	8	20	1.50	10	10
18	16	1.13	5-3/4	6-1/4	24	1.25	7-3/4	8-1/4	20	1.63	10-3/4	10-3/4
20	20	1.13	6-1/4	6-3/4	24	1.25	8	8-3/4	24	1.63	11-1/4	11-1/2
24	20	1.25	6-3/4	7-1/4	24	1.50	9	10	24	1.88	13	13-1/4

Nominal Pipe Size	900 LB. Flanges				1500 LB. Flanges				2500 LB. Flanges			
	# Bolts or Studs	Dia of Bolts or Studs	Length of Stud		# Bolts or Studs	Dia of Bolts or Studs	Length of Stud		# Bolts or Studs	Dia of Bolts or Studs	Length of Stud	
			1/4 RF	RTJ			1/4 RF	RTJ			1/4 RF	RTJ
1/2	4	0.75	4-1/4	4-1/4	4	0.75	4-1/4	4-1/4	4	0.75	4 3/4	4 3/4
3/4	4	0.75	4-1/2	4-1/2	4	0.75	4-1/2	4-1/2	4	0.75	5	5
1	4	0.88	5	5	4	0.88	5	5	4	0.88	5-1/2	5-1/2
1-1/4	4	0.88	5	5	4	0.88	5	5	4	1.00	6	6
1-1/2	4	1.00	5-1/2	5-1/2	4	1.00	5-1/2	5-1/2	4	1.13	6	6
2	8	0.88	5-3/4	5-3/4	8	0.88	5-3/4	5-3/4	8	1.00	7	7
2-1/2	8	1.00	6-1/4	6-1/4	8	1.00	6-1/4	6-1/4	8	1.13	7-3/4	8
3	8	0.88	5-3/4	5-3/4	8	1.13	7	7	8	1.25	8-3/4	9
4	8	1.13	6-3/4	6-3/4	8	1.25	7-3/4	7-3/4	8	1.50	10	10-1/4
5	8	1.25	7-1/2	7-1/2	8	1.50	9-3/4	9-3/4	8	1.75	11-3/4	12-1/4
6	12	1.13	7-1/2	7-3/4	12	1.38	10-1/4	10-1/2	8	2.00	13-1/2	14
8	12	1.38	8-3/4	8-3/4	12	1.63	11-1/2	12-3/4	12	2.00	15	15-1/2
10	16	1.38	9-1/4	9-1/4	12	1.88	12-1/4	12-1/2	12	2.50	19-1/4	20
12	20	1.38	10	10	16	2.00	14-3/4	15-1/4	12	2.75	21-1/4	22
14	20	1.50	10-3/4	11	16	2.25	16	16-3/4	-	-	-	-
16	20	1.63	11-1/4	11-1/4	16	2.50	17-1/2	18-1/2	-	-	-	-
18	20	1.88	12-3/4	13-1/4	16	2.75	19-1/2	20-3/4	-	-	-	-
20	20	2.00	13-3/4	14-1/4	16	3.00	21-1/4	22-1/4	-	-	-	-
24	20	2.50	17-1/4	18	16	3.50	24-1/4	25-1/2	-	-	-	-

Dimensions are in inches